

TB-1 USER MANUAL

Toolbase fitted with collaborative bumper

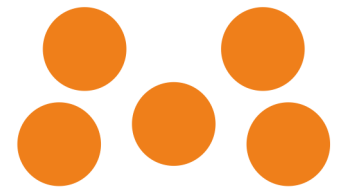



Preface

Congratulations with your TB-1 ToolBase.

No configuration needed, plug a tool and start to play.

The patented ToolBase supply anything needed for any connected tool and configures it instantly.

- Mechanical fixing using quick connector.
- Energy (pneumatic pressure, vacuum, electrical power)
- Communication to robot. (activation of tools + feedback status + more)

It has never been simpler to setup a robot for a new task.

In the box

1 TOOL BASE TB-1

1 Mounting plate for standard 31.5mm toolflange (ISO 9409-1-50-4-M6)

4 Mounting screws M6 x 9, TORX 25

4 O-ring 6x1.5

4 Mounting screws M4x12 including O-ring 3.5x1

1 TOOL I/O cable. (UR or Elfin)

1 Spare fuse 1A

2 Spare valve mounting screws. M2x14 (breakable)

1 Collaborative bumper

Important message.



The ToolBase and its attached Tools are part of a partly completed machinery. A risk assessment is required for each usage.

It is the responsibility of the robot integrator to make the risk assessment and that all safety requirements and local regulations are complied with.

Pneumatic gripping technology relies on stable electrical and compressed air supply. If supply is discontinued including control signals a picked item might drop.

Make sure there is no collisions between ToolBase including attached tools and other while maneuvering the robot.

Make sure ToolBase, quick coupling, Tools, gripper fingers, suction cups etc. are closed/mounted properly.

Never use a damaged ToolBase nor connect damaged tools.

The ToolBase is intended as industrial robotic end-effector. It is not to be used in potentially explosive environments or in life support applications.

Protect the ToolBase and its connected Tools from damaging chemical and physical effects including but not limited to: Corrosive substances, solvents, extreme temperatures, radioactive radiation, extreme magnetic fields, small

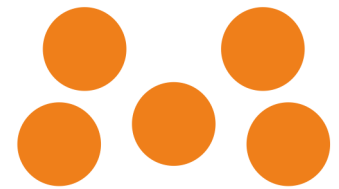

objects as powder/dirt, extreme mechanical vibrations, electrical currents and discharge.

Avoid touching the electrical connector in coupling. If a quick coupling is not in use it is recommended to mount a small suction cup or other to protect the coupling interface.

Installation

Place mountingplate on robot tool output flange. The plate is made with narrow tolerances. Make sure the parts are clean and placement is made in a axial movement with a minimum use of force.

Place a 6x1.5 O-ring on each M6x9 bolt and tighten to 8Nm.

Mount TOOL I/O cable on robot connector.



Caution.

M8 / M12 connector pins are very fragile. Make sure to align robot and cable connector keys before fitting and do not use force. (UR sample photo right)

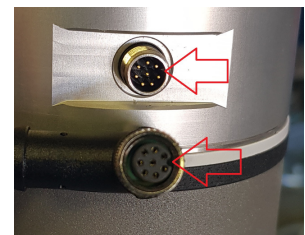

Place tool base on mounting plate.

Make sure surrounding O-ring is placed in its groove.

Place a 3.5x1 O-ring on each M4x12 bolt and tighten to 3Nm.

Mount TOOL I/O cable on tool base.

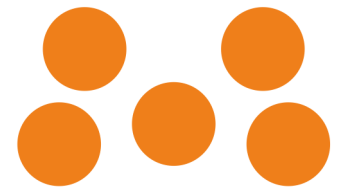

M8 connector pinout

PIN	Function
1	MODBUS RTU RS485 A
2	MODBUS RTU RS485 B
3	Feedback black (not used on singlebase)
4	Feedback white
5	24V
6	Activate black (not used on singlebase)
7	Activate white
8	GND

NPN / PNP for feedback and activate/control is set by switches before mounting on robot.

Connect 6bar clean dry air to tool base using 6MM pneumatic hose.

Multi functional I/O

One of the great advantages using the SetupRobotics toolbase is the multifunctional use of the very few I/O on a typical robot tool.

One output activates a tool

One input feedback status from a tool.

It is recommended to name TOOL I/O according coupling colors.

Rename tool IO pin 7 to oWhite (single and dual base)

Rename tool IO pin 6 to oBlack (dual base)

Rename tool IO pin 4 to iWhite (single and dual base)

Rename tool IO pin 3 to iBlack (dual base)

Set tool voltage to 24V

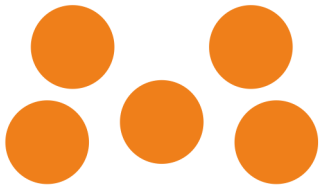

PICK and PLACE

PICK

To pick an object set the activate output high.

When the toolbase register the object is picked the feedback is set high for pneumatic and suction grippers. Feedback is high when object is present using magnet grippers.

If the object for some reason drops the input goes low again.

Object detection:

Pneumatic grippers	Finger position
Vacuum grippers	Vacuum pressure
Magnet grippers.	Object presence inductive sensor

PLACE

To place an object set the activate output low.

When the toolbase register the object is released the corresponding TOOL input is set low.

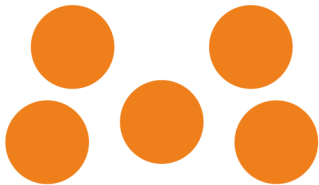

Overview toolbase

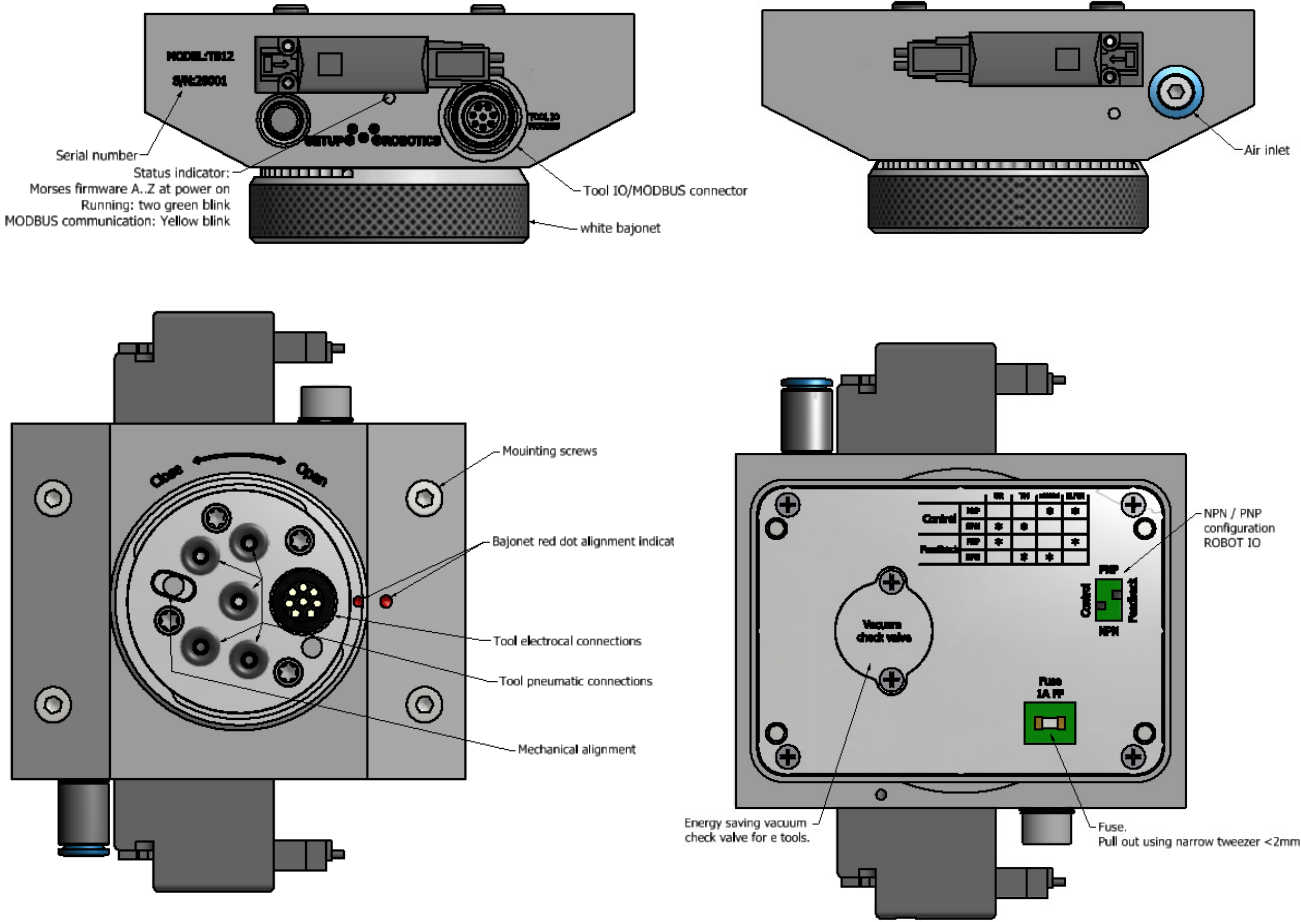

The toolbase utilizes two pneumatic valves. Via the patented configuration which is built into the connection between the tool and the base the same two valves can be used to control: pneumatic grippers, suction grippers dispensers and more.

The electrical tool connector informs the base which tool is connected so that the built-in controller can operate the valves specific for the mounted tool.

If a pneumatic gripper is mounted the two valves actuate the gripper in its two directions. Feedback is achieved via the grippers standard 2 (or 3) position sensors. Both external and internal gripping is possible.

If a suction gripper is mounted one valve feeds a vacuum ejector inside the base and the other valve provides the release pulse. Feedback is achieved via a pressure sensor built into the base.

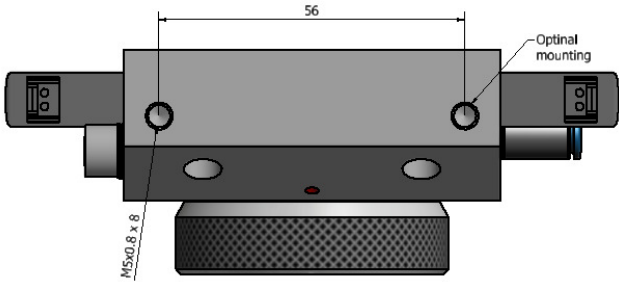

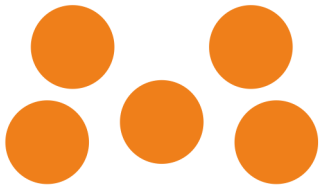

Quick coupling

Tool mounting

Align 2 x red dots on base and red dot on tool.
Gently insert tool into coupling.

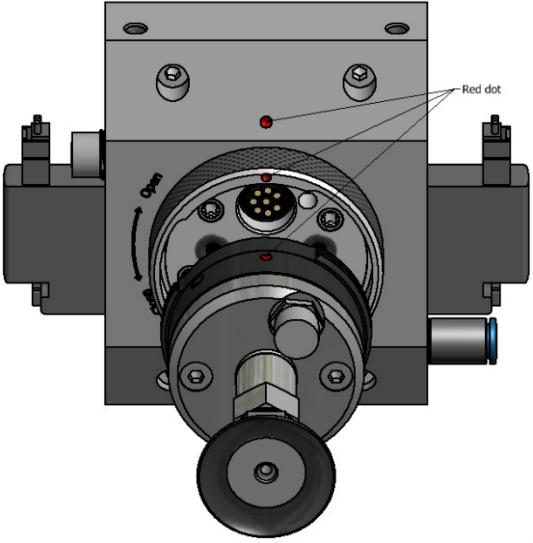

After inserting gently press tool into base and turn coupling ring.

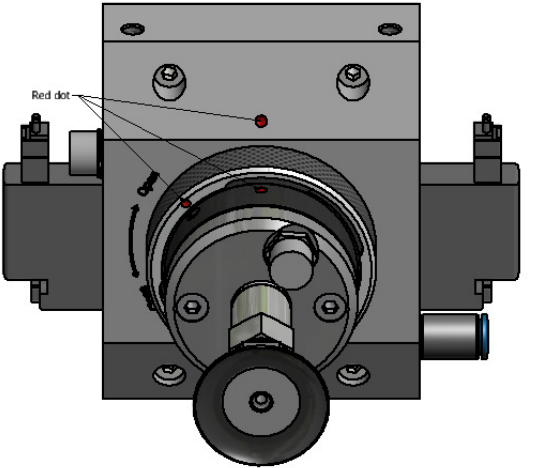

Opening

To open the coupling turn coupling ring to align 2 x red dots on base. Gently pull out the tool.



Caution.
Hold the tool secured while opening coupling so the tool not drops.



Caution.
Make sure electrical pins has no contact to any other mechanical parts than mating connector.

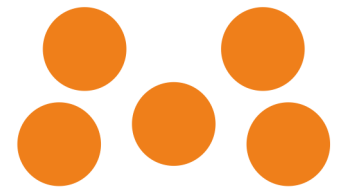



Technical data

Tool positions	1	[ul]
Size LxWxH	88x112x41	[mm]
Weight	375	[g]
Quick coupling repositioning tolerance	<0.075	[mm]
Operating voltage	24	[V]
Maximum current toolbase	100	[mA]
Air pressure	6	[bar]
Air usage (Vacuum generation)	12	[l/m]
Maximum vacuum	-0.85	[bar]
Maximum suction rate	6	[l/m]
Ambient operating temperature, non condensing	5..50	[°C]
Storage temperature, non condensing	0..60	[°C]

Wear and spare parts

Spare parts can be ordered from setuprobotics web-shop.

The pneumatic valves are mounted with breakable screws to minimize damage in the unlucky event of a collision	
Valve SMC V114A-5MU	
Fuse 1AF Littelfuse 0451001.NRL If the fuse is to be handled use a narrow (max 2mm) needle-nose pliers on fuse body.	

Contact

Web: www.setuprobotics.com
 Support: support@setuprobotics.com
 Sales: sales@setuprobotics.com



TB-1

Version:
1.04

Single robotic ToolBase

Page: 9/9

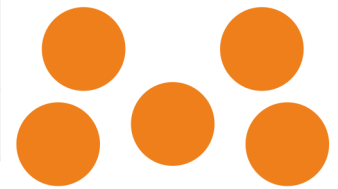

EC Declaration of conformity

Manufacturer:

SetupRobotics EU ApS
Industrivaenget 6B, Melose
3320 Skaevinge
Denmark

Hereby is certified that the following product:

Description:

Type

Production year

Serial No (from)

ToolBase

Industrial robotic ToolBase

TB-12

2020

1

is partly completed machinery according to 2006/42/EC.

The complete machine must be in full compliance with all essential requirements of 2006/42/EC before the toolbase and its connected accessories are put into service. A comprehensive risk assessment must be carried out for each application as part of ensuring that all essential requirements are fulfilled. All essential requirements must be assessed. Instructions and guidance provided in the manual must be followed.

The product is in conformity with the following directives:

2014/30/EU — Electromagnetic Compatibility Directive (EMC)

2011/65/EU — Restriction of the use of certain hazardous substances (RoHS)

2014/35/EU — Low Voltage Directive (LVD)

Uffe Safeldt
COO, CTO
Hillerød 2022.10.28